

THIS DRAWING IS UNPUBLISHED. RELEASED FOR PUBLICATION  
 © COPYRIGHT BY TYCO ELECTRONICS CORPORATION. ALL RIGHTS RESERVED.

LOC FT	DIST 0	REVISIONS			
P	LTR	DESCRIPTION	DATE	DWN	APVD
	B4	REVISED PER ECO-08-027445	11/4/08	MB	CR

MATERIAL:  
 HOUSING: PA66, UL94V-0, COLOR: SEE TABLE  
 PIN: BRASS, TIN PLATED  
 WIRE GUARD: BRASS, NICKEL PLATED  
 SCREWS: M4, STEEL, ZINC PLATED

ELECTRICAL:  
 VOLTAGE RATING: 300V  
 CURRENT RATING: 52A  
 CONTACT RESISTANCE: 200mohm  
 INSULATION RESISTANCE: 5000Mohm/1000V  
 WITHSTANDING VOLTAGE: AC2000V/1 MIN  
 WIRE RANGE: 6-8 STRANDED AND  
 10-20 SOLID OR STRANDED

MECHANICAL:  
 WORKING TEMP.: -40°C TO +105°C  
 MAX SOLDERING: +250°C FOR 5 SEC.  
 TIGHTENING TORQUE: 10.16 IN-LB

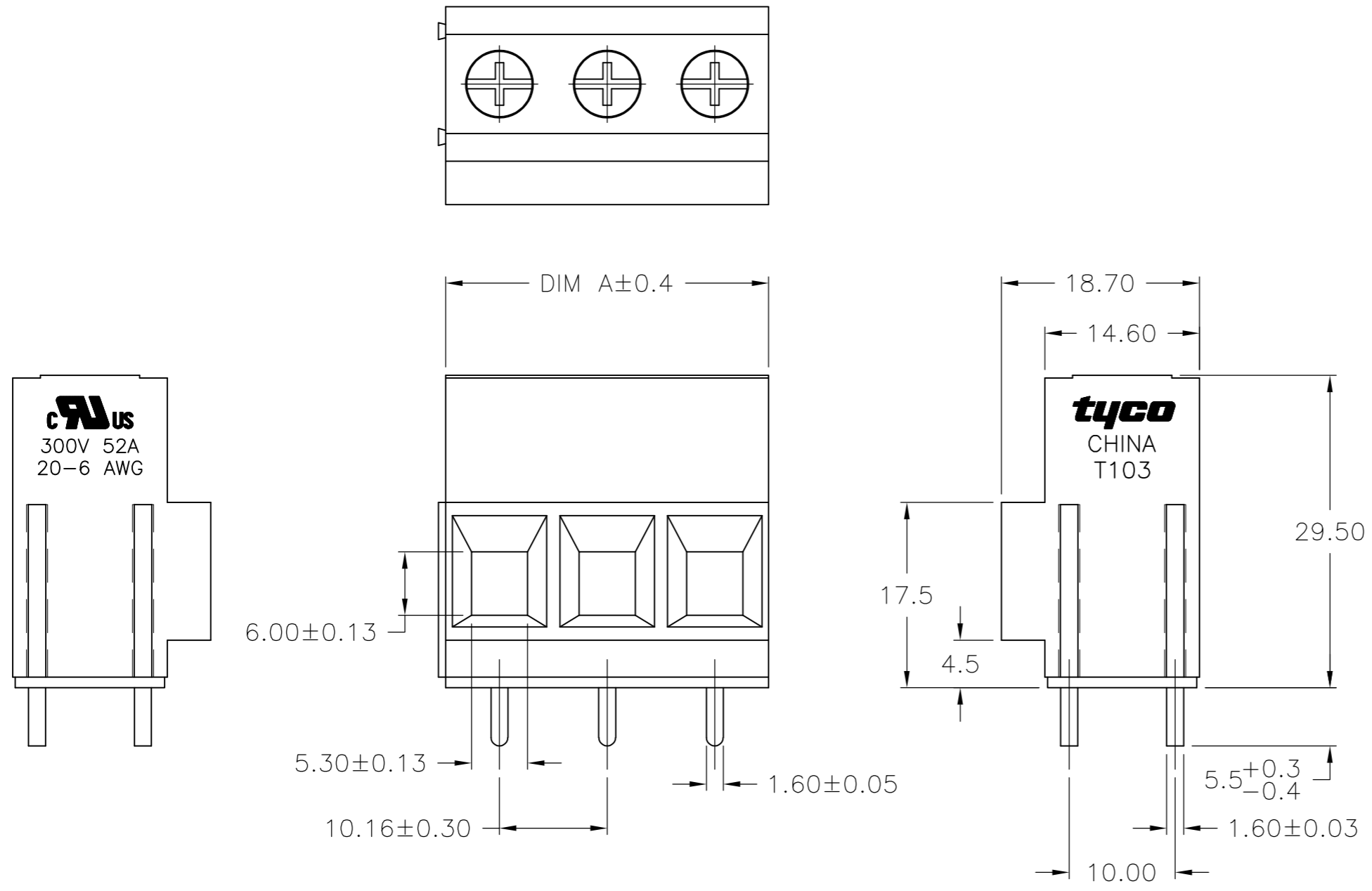

BLACK	30.48	3	1-1776886-3
BLACK	20.32	2	1-1776886-2
GREEN	30.48	3	1776886-3
GREEN	20.32	2	1776886-2
COLOR	DIM A	NO OF POS	PART NUMBER

THIS DRAWING IS A CONTROLLED DOCUMENT.		DWN S SCHLEGEL	25AUG2006	Tyco Electronics Corporation Harrisburg, PA 17105-3608	
DIMENSIONS: mm		CHK -	APVD -	NAME TERMINAL BLOCK, POWER CONNECTOR 10.16 PITCH	
TOLERANCES UNLESS OTHERWISE SPECIFIED:		PRODUCT SPEC -	APPLICATION SPEC -	SIZE A3	CAGE CODE 00779
0 PLC ± - 1 PLC ± 0.3 2 PLC ± 0.25 3 PLC ± - 4 PLC ± - ANGLES ± -		FINISH -	WEIGHT -	DRAWING NO C-1776886	RESTRICTED TO -
MATERIAL -		CUSTOMER DRAWING		SCALE 2:1	SHEET 1 OF 1
				REV B4	